

Thermoplastic Pipe Clamps up to d = 160 mm

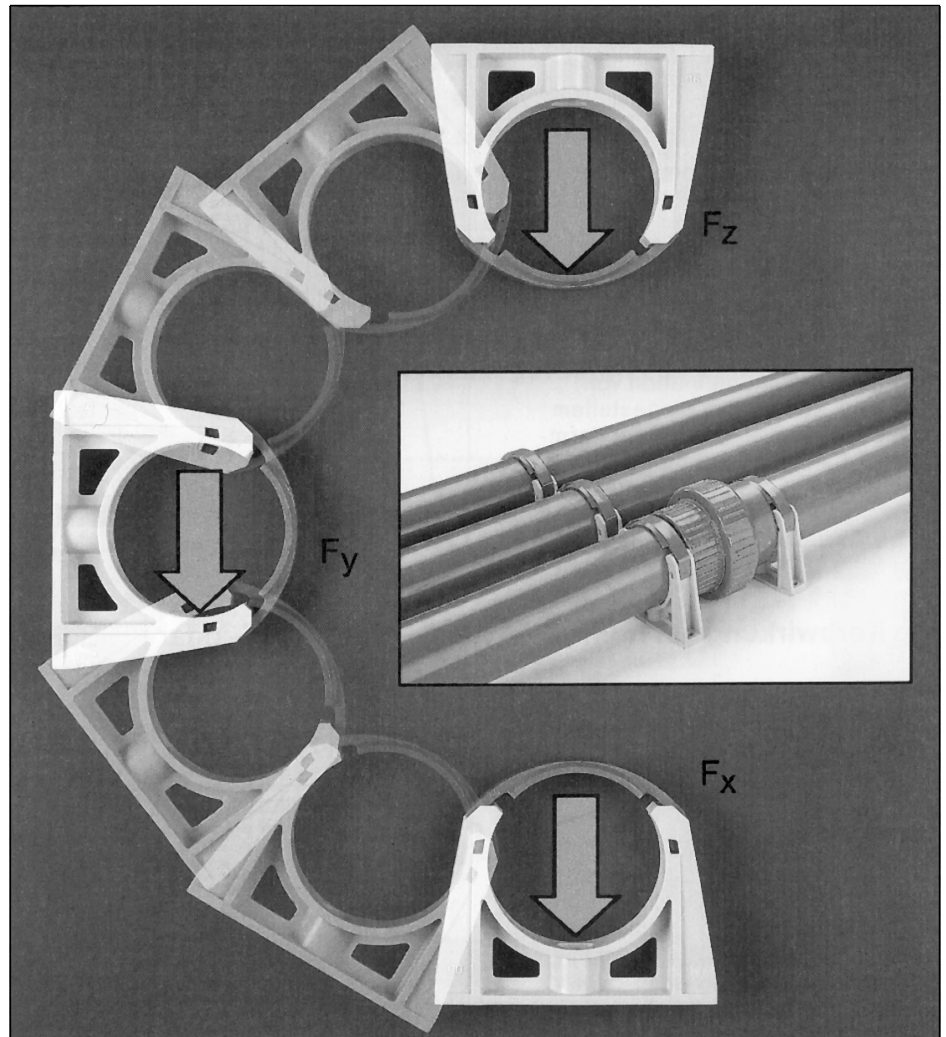

Horizontal, vertical or overhead installation

Optimal tube guiding

Ideal material combination

Safe tube fixing

For every industrial application

- with extreme loading in each direction
- safe fixing by 1 up to 3 screws
- free axial tube movability
- radial expansion capability at increased operating temperatures
- no clamping or notch effect on the tube
- quick and safe wall and ceiling mounting
- clamping body made of high quality **PP** and **HDPE**
- locking clip made of **PVC** with high impact strength
- for every loading case
- 350° pipe loop
- stable and durable safety clip
- in all branches of the chemical industry
- in plant and apparatus construction
- water treatment and sewerage technology
- for the general mechanical engineering

Pipe Clamps

Safe tube guiding with great application benefit

350° pipe loop with full breadth guarantees safe tube guiding for foot, wall or ceiling mounting. Due to the material combination of elastic deflection resistant PP or PE clamping body and dimensionally stable PVC locking clip the pipe clamp is self-locking. This important advantage should especially be considered for wall and ceiling mounting or for application with increased temperature.

- for high operating safety in permanent application
- constructive restricted ductility guarantees firm clamping
- 350° pipe loop wide supporting surface
- stable clamping guarantees safe locking

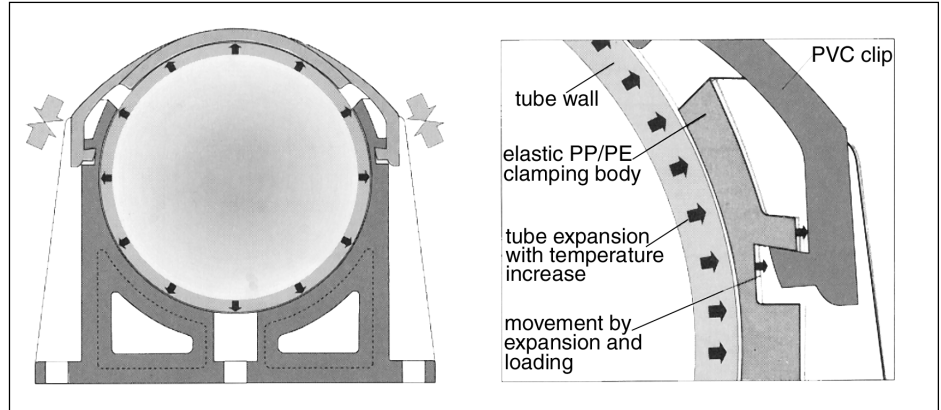

No clamping or notch effect on the tube

- elastic PP or PE clamping body
- shape construction ensures radial expansion capability at increased temperatures
- free axial tube movability (thermal elongation)

The sketch shows the free axial tube movability and radial expansion capability at increased temperatures. Pipe clamp as fixing point by installation on both sides of valves, fittings or by separate glued or welded pipe segments.

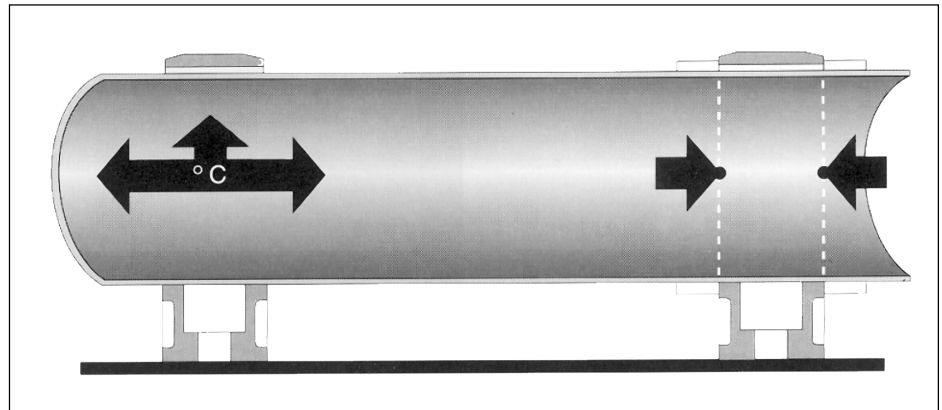

Easy handling

- wide supporting surface for fast mounting in each position
- safe locking without tools
- optimal and firm clamping
- easy and fast release

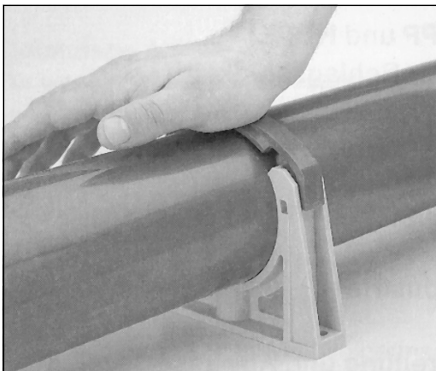

Locking without tools

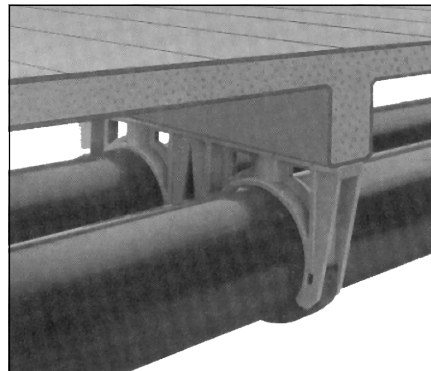

Safe clamping independent of position

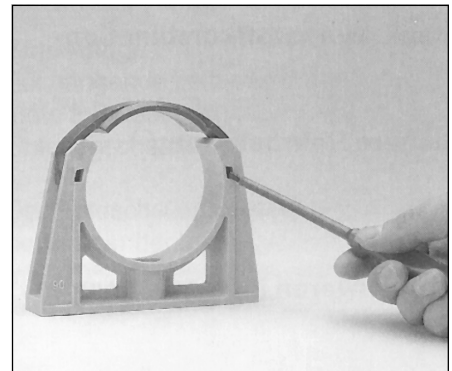

Easy release

Future orientated clamp technology

- meets all specifications acc. DIN 16928
- designed according to the additional requirements of the chemical industry VCI
- manufactured by state of the art injection moulding technology

High quality sturdy thermoplastic materials

- suitable for every tube and container material
- PP or HDPE with increased impact and fatigue strength

Practical dimensioning

- the top height cares for problem free installation of valves with tube connections acc. to DIN
- optimal clamp breadth for safe wall and economic tube mounting with small intermediate distances

Technical data

Material clamp body:

- PP (Polypropylene)
- HDPE (HD polyethylene)

Clip:

- uPVC

Operational and environmental temperatures:

- PP: - 10 up to + 80 °C
- HDPE: - 20 up to + 50 °C
- uPVC: - 10 up to + 60 °C

Colour:

- PP - grey, RAL 7032
- HDPE - black, RAL 9011
- uPVC - grey, RAL 7011

Other materials, colours on request.

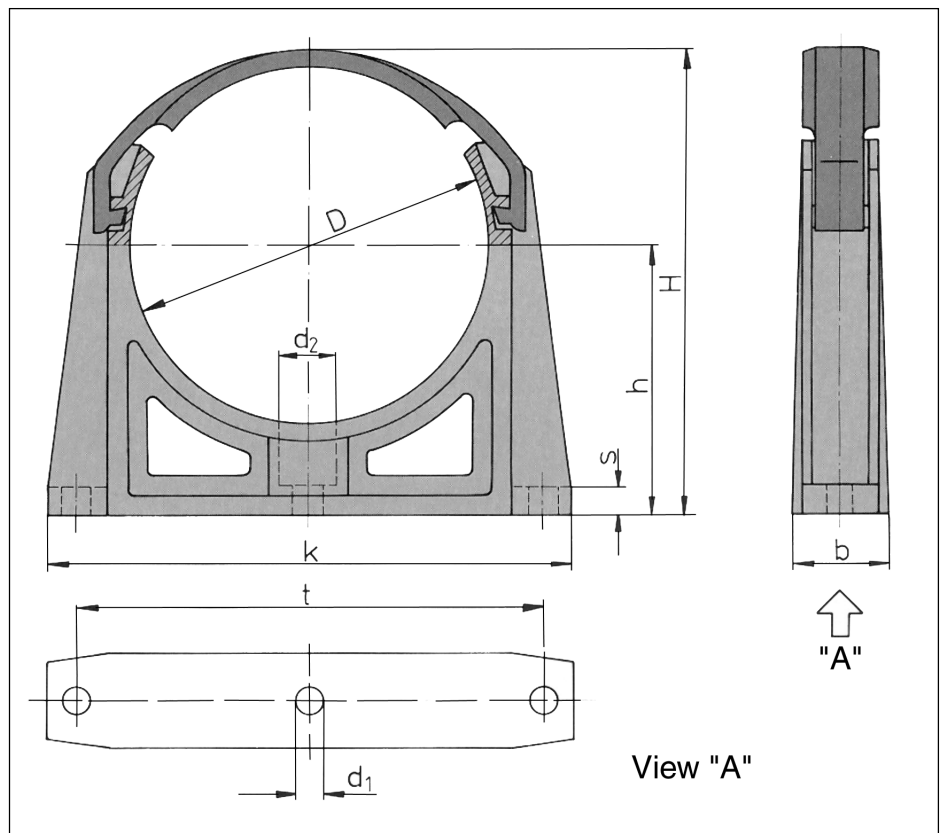

Dimensions mm											Ident-No. 1 x VPE ²⁾		Weight g/VPE ²⁾	
d ¹⁾	D	b	h	H	k	t	s	d ₁	d ₂	Z ³⁾	PP	HDPE	PP	HDPE
40	40,4	25	43	68	58	-	8	7	14,5	1	65928	41573	298	301
50	50,5	25	47	77	69	-	8	7	14,5	1	65929	41574	375	382
63	63,6	25	57	94	84	-	8	9	17,5	1	65930	41575	523	525
75	75,7	30	64	107	126	109	10	9	17,5	3	65931	41576	940	967
90	90,9	30	73	124	143	125	10	9	17,5	3	65932	41577	1230	1266
110	111,0	30	85	146	163	145	10	9	17,5	3	65933	41578	1523	1561
125	126,2	40	117	187	183	165	10	9	17,5	3	65934	41579	2463	2496
140	141,3	40	132	209	199	181	10	9	17,5	3	65935	41580	2915	3028
160	161,5	40	150	238	220	202	10	9	17,5	3	65936	41581	3145	3640

¹⁾ pipe OD

²⁾ VPE = one carton = 10 pieces

³⁾ quantity of fixing holes

Thermoplastic pipe clamps for operational safe tube support

- firm clamping even with extreme loading
- safe foot, wall or ceiling mounting
- self-locking clamping

The graph shows the clamping safety (%) against release of the pipe clamp. It refers to the intermediate clamp distances acc. DIN 16928 and same loads, e.g. specific gravity of the media.

For pipe clips d 16 up to 32 mm see data sheet 330 114, for pipe clips and brackets d 6 up to 28 mm see data sheet 330 115.

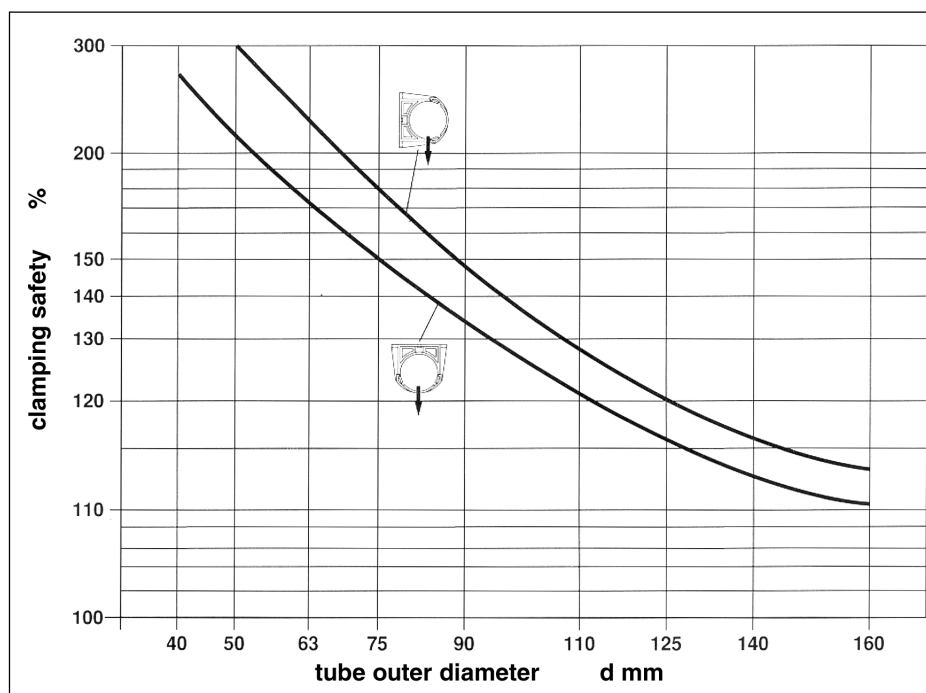

Fastening of pipe clamps with three-point fixation

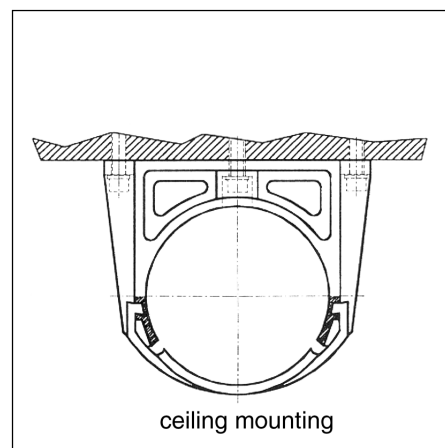
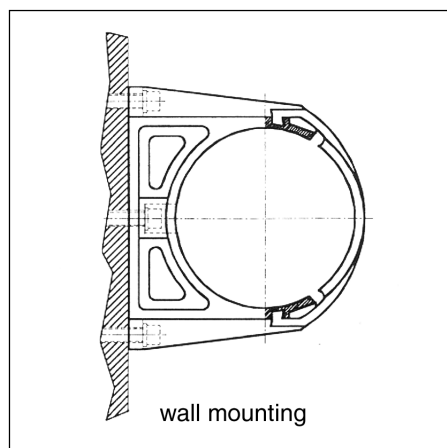
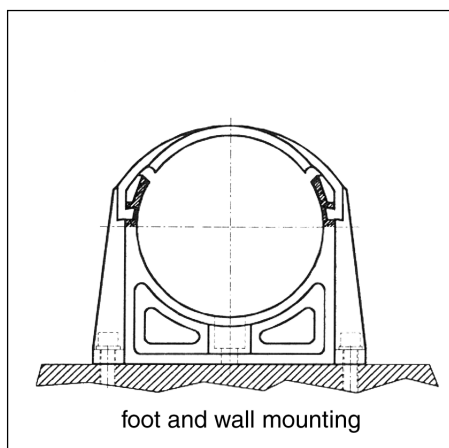

Position A

For horizontal and vertical tube guiding 2 fixation screws with washers have to be used. Intermediate distances (span) see data sheet 330 113.

Position B

For wall mounting horizontal tube guiding 3 fixation screws with washers have to be used. Intermediate distances (span) see data sheet 330 113.

Position C

For ceiling mounting do always use 3 fixation screws with washers. Intermediate distances (span) have to be limited to min 70 % of the respective span for horizontal tube guiding.

On applications with high thermal alterations do always use 3 fixation screws with washers.

Technical alterations excepted