

Schellen

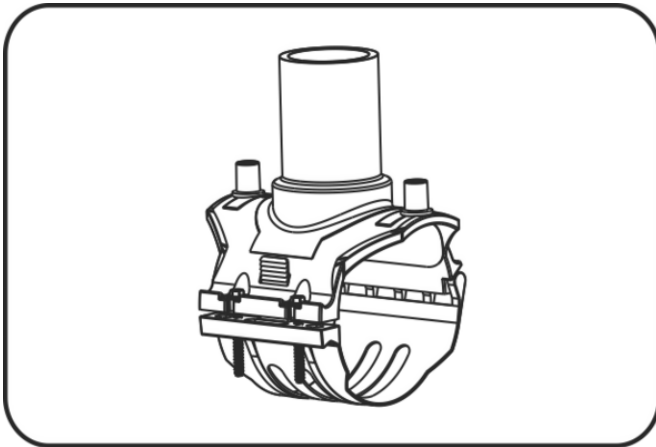

Code: 288

- **Stutzenschelle**
- MOP Wasser 16bar / Gas 10bar
- Unterteil schraubbar
- formgespritzt
- **Heizwendel-Schweissung**
- **PE 100-RC schwarz**

Dimension	Code	Detail	Einheit	Gewicht
90/20	70.288.9020.11	90/20 SDR 17 - 11	Stück	0.179
90/32	70.288.9032.11	90/32 SDR 17 - 11	Stück	0.28
90/40	70.288.9040.11	90/40 SDR 17 - 11	Stück	0.288
90/63	70.288.9063.11	90/63 SDR 17 - 11	Stück	0.26
110/20	70.288.1120.11	110/20 SDR 17 - 11	Stück	0.204
110/32	70.288.1132.11	110/32 SDR 17 - 11	Stück	0.272
110/40	70.288.1140.11	110/40 SDR 17 - 11	Stück	0.22
110/63	70.288.1163.11	110/63 SDR 17 - 11	Stück	0.357
125/20	70.288.1220.11	125/20 SDR 17 - 11	Stück	0.224
125/32	70.288.1232.11	125/32 SDR 17 - 11	Stück	0.229
125/40	70.288.1240.11	125/40 SDR 17 - 11	Stück	0.236
125/63	70.288.1263.11	125/63 SDR 17 - 11	Stück	0.323
140/20	70.288.1420.11	140/20 SDR 17 - 11	Stück	0.224
140/32	70.288.1432.11	140/32 SDR 17 - 11	Stück	0.35
140/40	70.288.1440.11	140/40 SDR 17 - 11	Stück	0.367
140/63	70.288.1463.11	140/63 SDR 17 - 11	Stück	0.323
160/32	70.288.1632.11	160/32 SDR 17 - 11	Stück	0.339
160/40	70.288.1640.11	160/40 SDR 17 - 11	Stück	0.428
160/50	70.288.1650.11	160/50 SDR 17 - 11	Stück	0.487
160/63	70.288.1663.11	160/63 SDR 17 - 11	Stück	0.51
160/90	70.288.1690.11	160/90 SDR 17 - 11	Stück	0.881
160/110	70.288.1611.11	160/110 SDR 17 - 11	Stück	0.949
180/32	70.288.1832.11	180/32 SDR 17 - 11	Stück	0.472

Dimension	Code	Detail	Einheit	Gewicht
180/40	70.288.1840.11	180/40 SDR 17 - 11	Stück	0.481
180/50	70.288.1850.11	180/50 SDR 17 - 11	Stück	0.565
180/63	70.288.1863.11	180/63 SDR 17 - 11	Stück	0.488
180/90	70.288.1890.11	180/90 SDR 17 - 11	Stück	1.005
180/110	70.288.1811.11	180/110 SDR 17 - 11	Stück	1.095
200/20	70.288.2020.11	200/20 SDR 17 - 11	Stück	0.269
200/32	70.288.2032.11	200/32 SDR 17 - 11	Stück	0.272
200/40	70.288.2040.11	200/40 SDR 17 - 11	Stück	0.278
200/63	70.288.2063.11	200/63 SDR 17 - 11	Stück	0.519
225/32	70.288.2232.11	225/32 SDR 17 - 11	Stück	0.464
225/40	70.288.2240.11	225/40 SDR 17 - 11	Stück	0.47
225/50	70.288.2250.11	225/50 SDR 17 - 11	Stück	0.53
225/63	70.288.2263.11	225/63 SDR 17 - 11	Stück	0.437
225/90	70.288.2290.11	225/90 SDR 17 - 11	Stück	0.942
225/110	70.288.2211.11	225/110 SDR 17 - 11	Stück	1.018
250/50	70.288.2550.11	250/50 SDR 17 - 11	Stück	0.376
250/63	70.288.2563.11	250/63 SDR 17 - 11	Stück	0.615
250/75	70.288.2575.11	250/75 SDR 17 - 11	Stück	0.731
250/90	70.288.2590.11	250/90 SDR 17 - 11	Stück	0.991
250/110	70.288.2511.11	250/110 SDR 17 - 11	Stück	1.068
280/50	70.288.2850.11	280/50 SDR 17 - 11	Stück	0.376
280/63	70.288.2863.11	280/63 SDR 17 - 11	Stück	0.55
280/90	70.288.2890.11	280/90 SDR 17 - 11	Stück	1.038
280/110	70.288.2811.11	280/110 SDR 17 - 11	Stück	1.068
315/63	70.288.3163.11	315/63 SDR 17 - 11	Stück	0.475
315/90	70.288.3190.11	315/90 SDR 17 - 11	Stück	1.059
315/110	70.288.3111.11	315/110 SDR 17 - 11	Stück	1.185
355/63	70.288.3563.11	355/63 SDR 17 - 11	Stück	0.619
355/90	70.288.3590.11	355/90 SDR 17 - 11	Stück	1.06
355/110	70.288.3511.11	355/110 SDR 17 - 11	Stück	1.19