

## Operating Instructions

**Type: MM-Xtruder**  
**230 Volt / 115V**

**Serial number:**

**P.O. No.:**

**P.O. date:**

Hand Extruder Ident Nos.:

230 V      K03969B    K04326B

115 V      K04180B    K04327B



**These operating instructions contain important information to be observed for hand extruder operation and maintenance.**

**It is therefore imperative that they be read and their contents fully understood by the operators before the hand extruder is placed in service.**



# Hand Extruder MM-Xtruder

---

## **Scope of delivery:**

Please check that the delivery is complete.

The delivery comprises:

1 hand extruder  
1 extruder stand  
1 welding shoe, machined  
3 air nozzles

1 hot air hood  
1 set of mounting tools  
1 transport case

# Contents

<b>1</b>	<b>GENERAL</b> .....	<b>5</b>
<b>2</b>	<b>SAFETY</b> .....	<b>5</b>
2.1	IDENTIFICATION OF INFORMATION IN THE OPERATING INSTRUCTIONS .....	6
2.2	PERSONNEL QUALIFICATION AND TRAINING .....	6
2.3	RISKS RESULTING FROM THE NON-OBSERVANCE OF THE SAFETY INSTRUCTIONS .....	6
2.4	SAFE WORKING PRACTICES .....	6
2.5	SAFETY INSTRUCTIONS FOR OPERATOR / OPERATING PERSONNEL .....	6
2.6	SAFETY INSTRUCTIONS FOR MAINTENANCE, INSPECTION AND MOUNTING .....	8
2.7	UNAUTHORIZED MODIFICATIONS AND SPARE PARTS .....	8
<b>3</b>	<b>TRANSPORT AND STORAGE</b> .....	<b>9</b>
3.1	TRANSPORT .....	9
3.2	STORAGE .....	9
3.3	RETURN TO MUNSCH .....	9
<b>4</b>	<b>PRODUCT DESCRIPTION</b> .....	<b>10</b>
4.1	APPLICATION RANGE .....	10
4.2	GENERAL DESCRIPTION .....	10
<b>5</b>	<b>STARTUP AND SHUTOFF</b> .....	<b>11</b>
5.1	GENERAL .....	11
5.2	PREPARATION .....	11
5.3	STARTING THE HAND EXTRUDER .....	12
5.4	WELDING WITH THE HAND EXTRUDER .....	13
5.4.1	<i>Introducing the welding rod</i> .....	13
5.4.2	<i>Replacement and aging of welding rod</i> .....	13
5.4.3	<i>Welding direction / rate</i> .....	14
5.4.4	<i>Work interruptions</i> .....	14
5.4.5	<i>Shutoff</i> .....	14
5.4.6	<i>Transport/Storage</i> .....	15
5.5	SET TEMPERATURES ON TEMPERATURE CONTROLLER .....	15
5.5	<i>Set temperatures</i> .....	157
<b>6</b>	<b>MAINTENANCE / INSPECTION</b> .....	<b>18</b>
6.1	MAINTENANCE / INSPECTION OF HAND EXTRUDER, .....	18
	TYPE MM-XTRUDER .....	18
6.2	DISMANTLING .....	18
6.2.1	<i>Hand extruder, type MM-Xtruder</i> .....	18
<b>7</b>	<b>MALFUNCTIONS, CAUSES AND REMEDIES</b> .....	<b>22</b>
7.1	TROUBLE-SHOOTING .....	22
7.2	FAULT DIAGNOSIS .....	22
<b>8</b>	<b>TECHNICAL DATA</b> .....	<b>24</b>

# Hand Extruder MM-Xtruder

---

## EG-Konformitätserklärung des Herstellers nach der EG-Maschinenrichtlinie 2006/42/EG Anhang II, Nr. 1 A EC-Declaration of Conformity by the Manufacturer as defined by machinery directive 2006/42/EC, Annex II, No. 1 A



MUNSCH Kunststoff-Schweißtechnik GmbH  
Im Staudchen  
D-56235 Ransbach-Baumbach  
Germany

Mr. Johann Dausenau,  
Kunststoffschweißtechnik GmbH,  
is authorised to compile the technical documentation.

We hereby declare that the hand extruders

Machine type: Hand extruder  
Type designation: MM-Xtruder

are in accordance with all relevant provisions of the EC Machinery Directive.

The following harmonised standards (or parts of these standards) were applied:

<input checked="" type="checkbox"/> <u>DIN EN ISO 12100-1: 2004</u>	<input checked="" type="checkbox"/> <u>DIN EN 13732-1: 2008</u>
<input checked="" type="checkbox"/> <u>DIN EN ISO 12100-2: 2004</u>	<input type="checkbox"/> _____

In addition, the hand extruders are in accordance with the following EC-directives, standards, codes and regulations:

<input checked="" type="checkbox"/> <u>EU Low-Voltage Directive 73/23/EC</u>	<input checked="" type="checkbox"/> <u>EU EMC Directive 89/336/EC</u>
<input checked="" type="checkbox"/> <u>EN 60204-1 (VDE 0113 Part 1): 2007</u>	<input checked="" type="checkbox"/> <u>DIN EN 55014-1: 2007</u>
<input checked="" type="checkbox"/> <u>EN 61029-1 (VDE 0740 Part 500): 2003</u>	<input checked="" type="checkbox"/> <u>DIN EN 55014-2: 2009</u>
<input checked="" type="checkbox"/> <u>VDE 0701 Part 1: 2008</u>	<input type="checkbox"/> _____
<input checked="" type="checkbox"/> <u>VDE 0702 Part 1: 2003</u>	<input type="checkbox"/> _____

This industrial tool complies with the aforesaid standards insofar as it is used at the contractually agreed conditions. The operator is responsible for this.

In the event of any modifications to the machine/unit or use not as intended, this declaration becomes invalid unless the manufacturer's prior written approval has expressly been given.

Ransbach-Baumbach, 29.12.2009

  
Dipl.-Ing. Stefan Munsch  
Managing Director

## 1 General



**These operating instructions must always be available at the place of use of the hand extruder.**

The objective of these operating instructions is to support operators in familiarizing themselves with the hand extruder and in using its functions for the intended service.

These operating instructions provide important information for the safe, workmanlike and economical operation of the hand extruder. Their observance helps avoid danger, minimize repair costs and downtimes, enhance reliability, and extend the service life of the hand extruder.

Any person performing work with/on the hand extruder is required to read the operating instructions. Such work includes, for instance:

- operation,
- maintenance, inspection and repair
- transport.

The hand extruder may only be mounted, operated and maintained by trained personnel.

In addition to the operating instructions and the national and local accident prevention regulations applicable at the place of use, the acknowledged technical rules for safe and proper working practices must be observed.

These operating instructions provide basic information to be observed for operation and maintenance. For this reason, it is imperative that they be read by the specialist personnel/Operator prior to placing the hand extruder in service and that they always be available at the place of use. Apart from the general safety instructions under section "Safety", also the special safety instructions given under the respective sub-sections must be adhered to.



**Non-observance of the safety instructions may cause hazards to persons and the environment or damage to the hand extruder.**

Moreover, failure to observe the safety instructions may lead to the forfeiture of any damages.

Non-observance of the safety instructions may in particular involve the following risks:

- failure of important hand extruder functions,
- hazards to persons due to electrical and mechanical impacts including risk of burns,
- hazards to the environment due to vapour-phase hazardous substances,
- risk of fire.

## 2 Safety

These operating instructions provide basic information to be observed for operation and maintenance. For this reason, it is imperative that they be read by the specialist personnel/Operator prior to placing the hand extruder in service and that they always be available at the place of use.

Safe operation of the hand extruder presupposes that the instructions under section 1 – General – of these operating instructions are complied with. In no case must the limit values indicated be violated.

Intact and unaltered hand extruders conform to the applicable codes and standards and meet all regulatory limit values regarding EMC (electromagnetic discharges and interference immunity). For the country-specific limit values to be observed, the Operator should consult the local electric utility. Nevertheless, the hand extruders emit electromagnetic fields within the acceptable limits. Electromagnetic fields may interfere with the operation of vital electronic devices (e.g. cardiac pacemakers). Persons wearing a cardiac pacemaker should therefore consult their physician before using the machine.

In addition to the operating instructions and the national and local accident prevention regulations applicable at the place of use, the acknowledged technical rules for safe and proper working practices must be observed.

Apart from the general safety instructions under section "Safety", also the special safety instructions given under the respective sub-sections must be adhered to.

Any working practices posing a safety risk are prohibited.

# Hand Extruder MM-Xtruder

## 2.1 Identification of information in the operating instructions

In these operating instructions, safety instructions whose non-observance may cause hazards to persons are identified with



Hazard symbol according to DIN 4844 – W 9

for general hazards and with



Hazard symbol according to DIN 4844 – W 8

for electrical hazards.

Safety instructions whose non-observance may cause damage to the hand extruder and its functions are marked with

**CAUTION**

Instructions directly indicated on the hand extruder must be strictly followed and kept in a fully legible state.

## 2.2 Personnel qualification and training

The operating, maintenance and inspection personnel must possess appropriate qualification for the work to be performed. Functional and technical responsibilities and supervision of the operating personnel must be clearly regulated by the Operator. Where the personnel do not have the necessary skills and knowledge they must be trained and instructed (e.g. a DVS basic welder training in extrusion welding). A detailed instruction into hand extruder operation will be provided by the Manufacturer / Supplier on request. Furthermore, the Operator has to make sure that the contents of the operating instructions is fully understood by the operating personnel.

## 2.3 Risks resulting from the non-observance of the safety instructions

Non-observance of the safety instructions may cause hazards to persons and the environment or damage to the hand extruder. Moreover, failure to observe the safety instructions may lead to the forfeiture of any damages.

Non-observance of the safety instructions may in **particular** involve the following risks:

- failure of important hand extruder functions,
- hazards to persons due to electrical and mechanical impacts including risk of burns,
- hazards to the environment due to vapour-phase hazardous substances,
- risk of fire.

## 2.4 Safe working practices

The safety instructions given in these operating instructions, the applicable national accident prevention regulations and any existing in-company work instructions, operating and safety procedures issued by the Operator are to be followed.

## 2.5 Safety instructions for Operator / operating personnel

- Before placing the hand extruder in service, check the mains voltage and frequency against the data indicated on the type tag. The allowable tolerances are  $\pm 5\%$  for voltage and /or  $\pm 2\%$  for frequency.
- According to VDE 0100 §55, the hand extruder must be operated via a residual current-operated circuit breaker or an isolating transformer.
- **CAUTION** During hand extruder operation (under load), a voltage of not less than 230 V<sup>1)</sup> (115V)<sup>2)</sup> must be available at the connector of the hand extruder.
- When using an extension cable, make sure to observe the minimum conductor cross-section. Use extension cables with protective conductor only.

Length [m]	Minimum cross-section [mm <sup>2</sup> ]
up to 19	4.0 <sup>1)</sup>
20-50	6.0 <sup>1)</sup>

1) for 230 V AC

2) for 115 V AC

- Extension cables must be certified for the specific service conditions (e.g. outdoor service) and identified accordingly.

Always handle the connecting cable with care.

- Do not kink the connecting cable.
- Do not place any objects on the cable.
- Do not jam or squeeze the connecting cable, nor pull it over sharp edges.
- Protect the connecting cable from moisture.

-  Do not touch the mains connector or connecting cable with wet hands. Hold the cable always at the connector when plugging or unplugging it.

- **CAUTION** Power generator sets used for power supply must be designed for the following rated output:

≥ 4 x rated output of hand extruder

-  Never allow the hand extruder to come into contact with water: Hazard to persons and equipment, short-circuit risk.

- **CAUTION** Never operate the hand extruder without air supply; risk of hand extruder damage.

When using an external air source, make sure that the air supply line is adequately dimensioned.

- **CAUTION** The supply air must be clean, dry and free from oil and water.

-  The hand extruder must not be used in explosion hazard areas or flammable atmospheres.

Make sure to stand on a firm base when operating the hand extruder.

The connecting cable, welding rod and hose for external air supply, if applicable, must be freely movable and must not obstruct the operator or third parties in their work.

-  Hold and touch the hand extruder only on the handles provided for this purpose.

- **Do not** touch bare metal parts (including hot air hood) either with or without gloves. These parts reach temperatures of up to 450 °C.
- Attachments may be damaged or impaired in their function if subjected to the full weight of the hand extruder.
- Bare metal parts must not come into contact with other items during the work or work breaks (e.g. cooling).

FIG. D02-0001

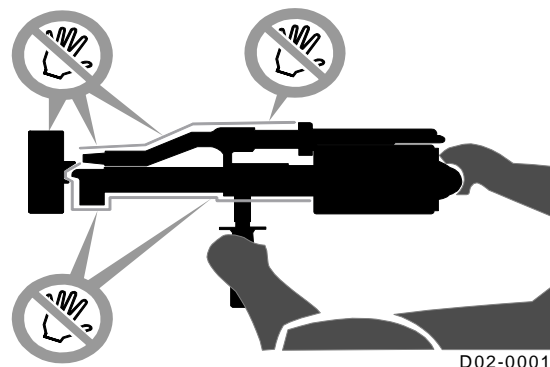

-  **Contact of combustible components with hot bare metal parts poses a risk of fire!**

**Do not use synthetic gloves!**

# Hand Extruder MM-Xtruder

- Do not direct the hot air jet of the hand extruder towards living beings or temperature-sensitive items.

Safety distance: 2 m radius

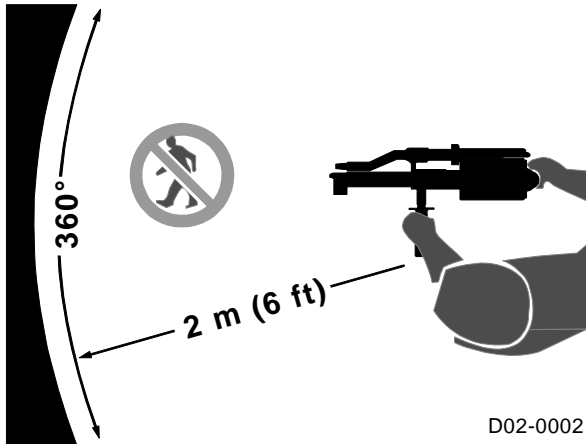

- Use suitable personal protection equipment for overhead work (e.g. hard hat, safety goggles, gloves, protective clothes ...) to guard against falling items.
- During work breaks and after completion of the welding job, place the hand extruder on the rests supplied for this purpose.



**CAUTION** The hot air hood must be remounted.



Make sure that the hand extruder is firmly positioned!

Deposit hand extruder in a dry location.

After completion of the welding job, cool the hand extruder to safe-to-touch temperature, using the air supply system.

-  Do not operate, dismantle or carry out modifications on the hand extruder, if
  - the connecting cable or the mains connector is defective,
  - safety devices are damaged,
  - foreign matter or liquid has penetrated into the hand extruder,
  - the unit does not work properly or there are unusual changes in the operating behaviour.
-  Never allow the hand extruder to come into contact with water: Hazard to persons and equipment, short-circuit risk.

## 2.6 Safety instructions for maintenance, inspection and mounting

The Operator is responsible for ensuring that maintenance, inspection and mounting activities are performed by authorized and **qualified personnel** who are thoroughly familiar with the operating instructions.

- As a rule, the hand extruder must be shut off and the connector unplugged before proceeding to any work on the unit. The shutoff procedure for the hand extruder described in the operating instructions must be strictly observed.
- Electrical hazards must be ruled out (for details, see VDE guidelines and the standards of your local electric utility, for instance).

-  VDE 0701 (IEC 335) prescribes the measurement of the protective conductor resistance, insulation resistance and leakage current after each repair or modification to electrical equipment. Furthermore, a visual inspection of the unit and its connecting cable as well as voltage and current measurements and a function test must be carried out.
- Ensure the safe and environmentally compatible disposal of media, auxiliary materials and replaced parts!
- Remount and reactivate all safety and protective devices immediately on completion of the maintenance, inspection or repair work.



## 2.7 Unauthorized modifications and spare parts

Modifications or changes to the unit are only allowed after consultation with the Manufacturer. In the interest of safety, only original spare parts and accessories authorized by the Manufacturer should be used. The use of components other than the original spare parts may invalidate Manufacturer's liability for any resulting damage.



### 3 Transport and Storage

#### 3.1 Transport

-  Before transport or storage, make sure that the hand extruder has cooled down to safe-to-touch temperature.
-  Hold and touch the hand extruder only on the handles provided for this purpose.

**Do not** touch bare metal parts (including the hot air hood) – whether with or without gloves – before having made sure that they are safe to touch. These parts reach temperatures of up to 450 °C during operation

FIG. D02-0001

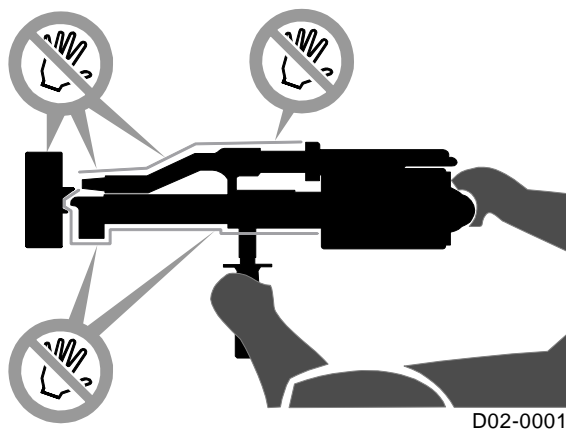

- Never transport or store the hand extruder in such a way that the attachments are exposed to mechanical loads.

If parts have been removed for transport purposes, mount and fasten them carefully before restarting the hand extruder!

Transport of the hand extruder in MUNSCH's original shipping case is recommended.

- For transport of the hand extruder, the transport case supplied together with the unit must be additionally packed using appropriate shock-proof packaging.

#### 3.2 Storage

- Store the hand extruder in a dry and frost-free place.
- Protect the hand extruder from unauthorized access.
- Special preservation is not required.

#### 3.3 Return to Munsch

Should it become necessary to return the hand extruder to MUNSCH Kunststoff-Schweißtechnik GmbH, always use the original shipping case.

For transport of the hand extruder, the transport case supplied together with the unit must be additionally packed using appropriate shock-proof packaging.

# Hand Extruder MM-Xtruder

## 4 Product Description

### 4.1 Application range

The application range of the hand extruder is defined by the data on the type tag and the service limits indicated in these operating instructions.

**CAUTION** Operation of the hand extruder outside the application range stated in these operation instructions is subject to the Manufacturer's prior approval.

### 4.2 General description

The type **MM-Xtruder** is a hand extruder with integrated air supply (Autoair).

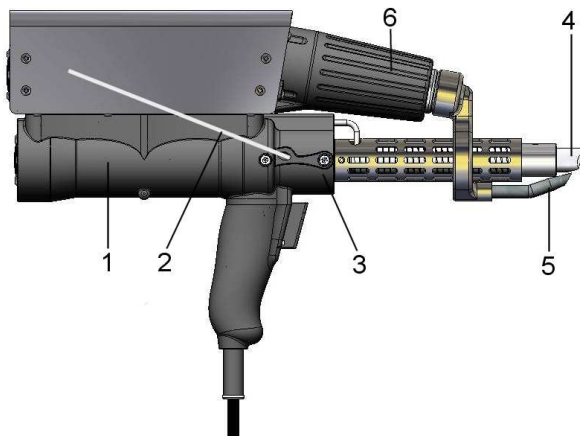

**CAUTION!**

Use 3 mm welding rod exclusively.

**CAUTION** Too low a speed will pose a risk of drive overheating!

Driven by a powerful electric motor (1), the welding rod (2) is fed into the extruder (3) and granulated by the extruder screw in the process. The screw forces the granulate into the extruder nozzle, melting it into a homogeneous, completely plastified mass. As the molten material exits the extruder nozzle, it is moulded by a welding shoe (4) to the geometry of the weld seam to be deposited

Preheating of the parts to be joined is achieved by a preheat nozzle (5) which is supplied from an on-board hot air unit (6). Air supply is via an on-board blower.

The melt and preheat air temperatures are controlled separately. The set point and momentary values are displayed concurrently.

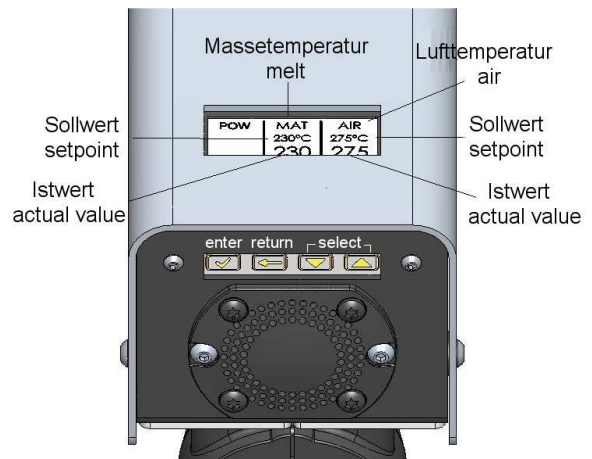

For the drive interlock to be released for starting, the melt and preheat air temperatures must be above the start interlock temperature and the startup timer must have timed out. The **start interlock temperature** and the **startup time** can be separately set for the melt and preheat air.

The temperature-controlled start interlock prevents the drive from starting if there is still unmolten material in the extruder, thus precluding damage to the unit.

The output rate is variable so that the preheat time can be matched to the weld thickness

## 5 Startup and Shutoff

### 5.1 General

In addition to the operating instructions and the national and local accident prevention regulations applicable at the place of use, the acknowledged technical rules for safe and proper working practices must be observed.

Any working practices posing a safety risk are prohibited.

Before starting / shutting off the hand extruder, make sure to carefully read the instructions under section "Safety".

**Only trained and qualified personnel may be assigned to the operation of the hand extruder.**

- Mount hot air hood (128) to the heat guard (115) of the melting chamber.

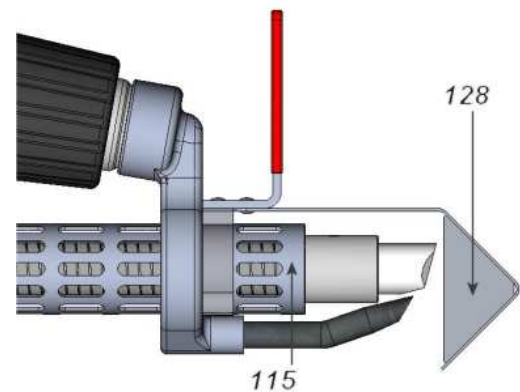

### 5.2 Preparation

- Place hand extruder with stand on a firm support.



- Mount welding shoe
  - Select the welding shoe required for the specific weld geometry or machine a welding shoe blank to the required geometry.
  - Welding shoe (Item 1), to the hand extruder in the position required for welding mount. **Observe welding direction!** 2 x Tighten set screw (25).
  - There are different welding shoe types. For their mounting, proceed in analogy with the above procedure.

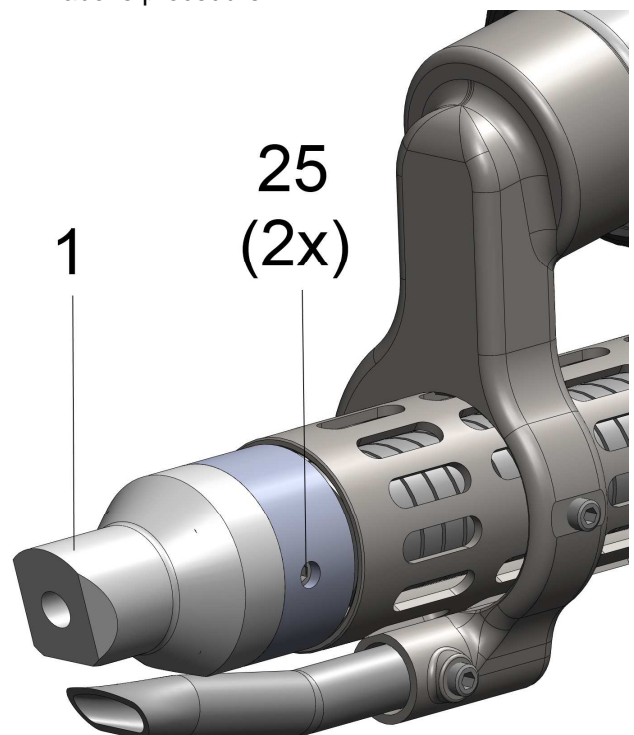

# Hand Extruder MM-Xtruder

- Mount preheat nozzle
  - Select and mount the preheat nozzle (4) required for the specific weld geometry.
  - Observe spacing  $A = 5 \text{ mm}$ .
  - Tighten the preheat nozzle using the set screw (25.1).

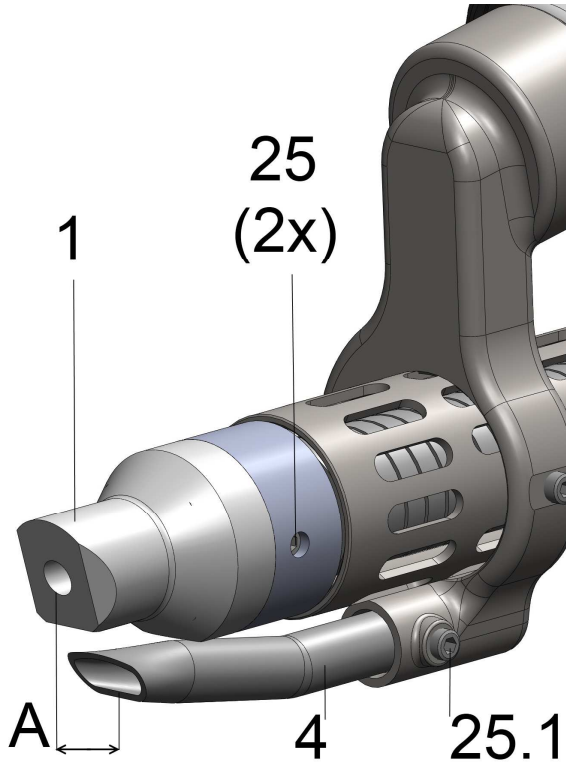

- **CAUTION** Before plugging in the mains connector, check that the drive unit is not set to continuous operation.
- **CAUTION** The hot air hood (128) must be mounted to the heat guard (115) of the hand extruder melting chamber.

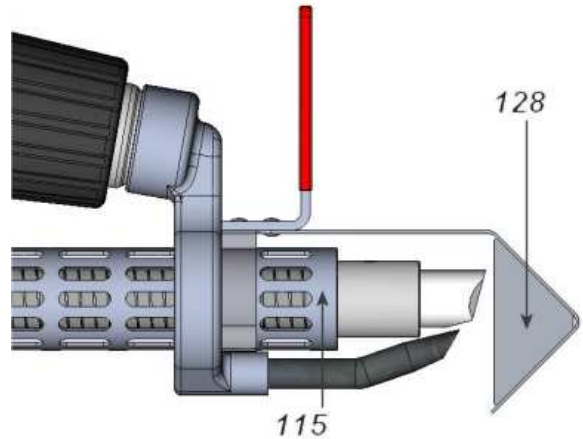

- **CAUTION** Plug in mains connector.
- **CAUTION** With the MM-Xtruder with integrated air supply, the on-board blower must start automatically.
- **CAUTION** Once air exits the preheat nozzle (4), the heating systems for the air/melt temperature may be activated.

**Table: Preheat nozzle (Item 4)**

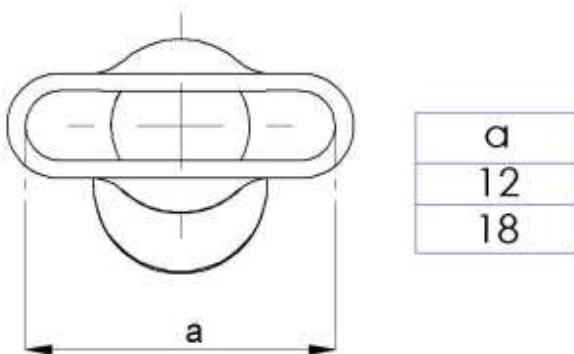

BA.EX008.10-00.Rev-00

Care must be taken to ensure that the preheat nozzle provides intensive and uniform preheating (melting) of the base material over the entire joint width at as low a hot air temperature as possible.

## 5.3 Starting the hand extruder



Observe section "Safety".

**CAUTION** Never operate the hand extruder without air supply. Otherwise the unit may suffer severe damage.

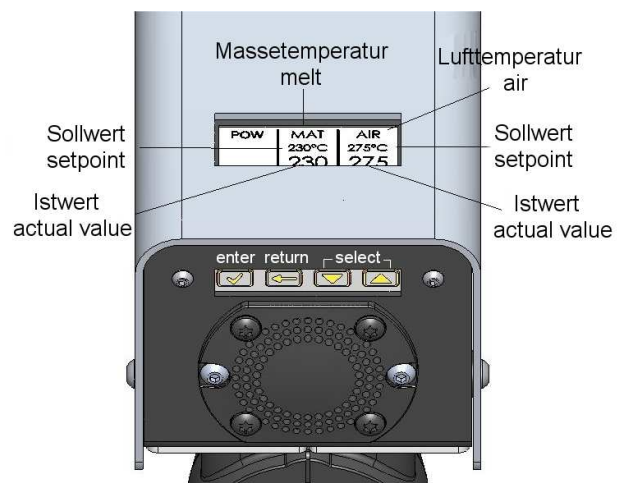

- For the operation of the temperature controller, see section 5.5 “Set temperatures”. For the temperature settings, please see page 15, “Temperature chart for MM-Xtruder”.

**The hand extruder will reach its operating temperature after about 10 to 15 minutes.**

- The drive speeds of the drive unit are set by default for the individual materials.

 Hold and touch the hand extruder only on the handles provided for this purpose.

FIG. D02-0001



D02-0001

- **CAUTION** The Start switch of the drive unit may only be operated after the operating temperature has been reached and the startup timer has timed out. Otherwise, the hand extruder may be damaged by solidified material still present in the machine. The hand extruder is equipped with a start interlock which prevents starting of the drive before the melting temperature of the welding rod is reached. For temperature settings, see page 15 “Temperature chart for MM-Xtruder”

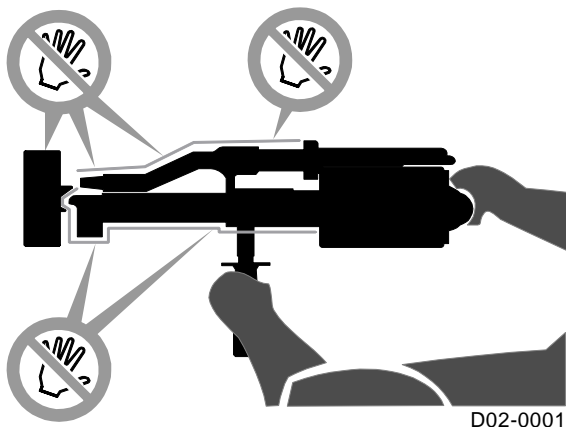
#### 5.4 Welding with the hand extruder

 Observe section “Safety” and the data sheet.

##### General

Welding is to be carried out in accordance with the guidelines of the German Association for Welding Technology (Deutscher Verband für Schweißtechnik DVS).

The parts to be joined and the welding rod must be clean and dry.

#### 5.4.1 Introducing the welding rod

- **CAUTION** The hand extruder is provided with a bore **B** for introducing the welding rod.

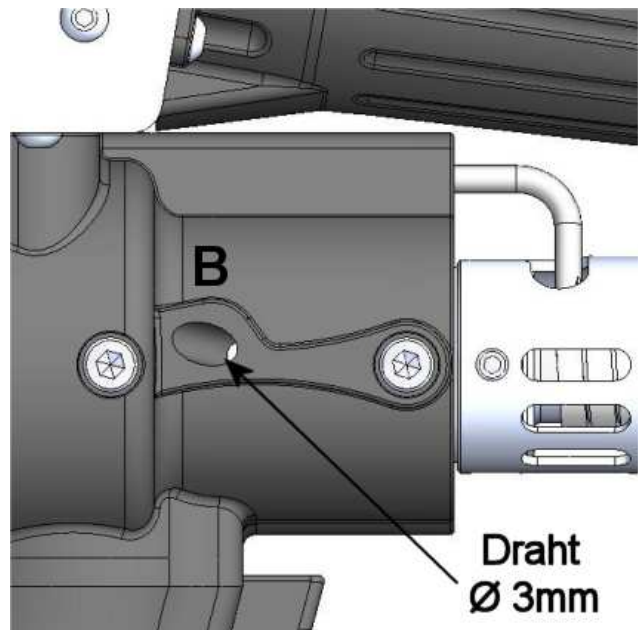

#### 5.4.2 Replacement and aging of welding rod

- If the welding rod is to be replaced, make sure that any remaining rod in the hand extruder is completely removed.
- For this purpose, operate the preheated hand extruder with the new welding rod until clean new material discharges.
- The DVS guideline also recommends this procedure for hand extruders which have been out of service for prolonged periods while still being filled with welding rod.
-  Ensure safe and environmentally compatible disposal of any waste generated!



# Hand Extruder MM-Xtruder

## 5.4.3 Welding direction / rate

- The pressure of the discharging extrudate causes the welding shoe (and hence, the hand extruder) to move in welding direction.
- See DVS Guideline for the welding rate.

FIG. D02-0026

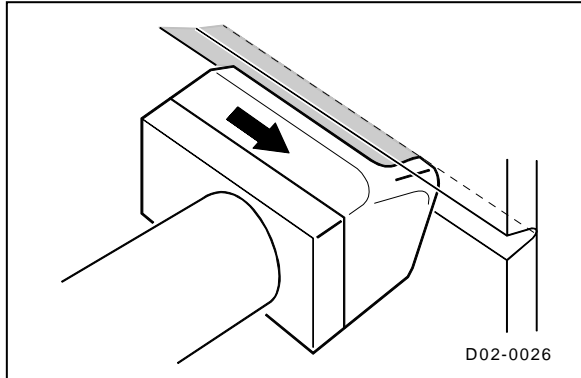

## 5.4.4 Work interruptions

-  Observe section "Safety".  
Do not leave the hand extruder unattended.  
Make sure to maintain the air supply.
- When interrupting the welding job, switch off the drive unit and deposit the hand extruder on the stand as shown in Fig. "A" below and then mount the hot air hood.

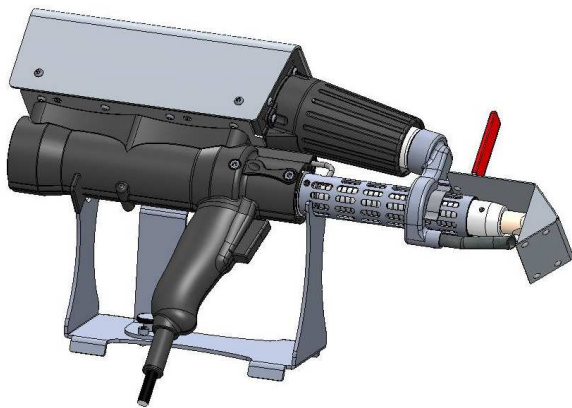



FIGURE "A"

- When using PVC welding rod, we recommend not to switch off the unit during work interruptions. In the case of prolonged interruptions, clean the unit by feeding PP rod until all the PVC material has been discharged.
- Caution! When displacing the PVC with PP rod, set the material to PP on the control unit.

## 5.4.5 Shutoff

 Observe section "Safety".

- After completion of the welding job, switch off the drive unit and deposit the hand extruder as shown in Fig. "A" (for illustrations, see preceding section).

 Do not leave the hand extruder unattended.

### 5.4.5.1 Hand extruder with integrated air supply, type MM-Xtruder

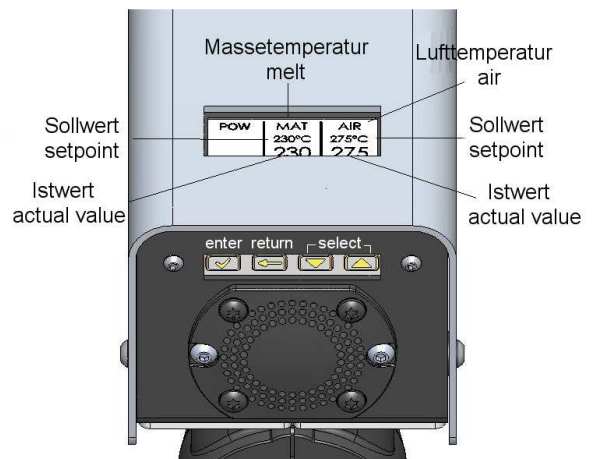



-  Maintain the air supply after switching off the hand extruder until the unit has completely cooled down!
- Pull mains connector.

 **Never use water or another coolant to accelerate the cooling process!**

### 5.4.5.1 Hand extruder, type MM-Xtruder

- Press “return” button to switch off the heating circuits.
- Allow extruder to cool for 10 minutes.
- Pull mains connector of hand extruder.

-  Do not switch off the hand extruder until after the unit has completely cooled down!

 **Never use water or another coolant to accelerate the cooling process !**

### 5.4.6 Transport/Storage

Make sure to observe the instructions under section “Transport/Storage”.

## 5.5 Set temperatures on temperature controller

The default settings for the melt and air temperatures of the MM-Xtruder are shown in the following temperature chart (these values have been determined with the aid of reference materials).

### Temperature chart for MM-Xtruder

Material	Melt temperature	Air temperature
PP	210 – 240°C	250 – 300°C
PE	210 – 230°C	250 – 300°C
PVC-U	180 – 200°C	300 – 360°C
PVC-C	195 – 205 °C	300 – 360°C
PVDF	240 – 260°C	280 – 350°C

If other temperatures and materials are needed the corresponding settings can be made on the temperature controller.

## 5.5 Set temperatures

See the user instructions overleaf

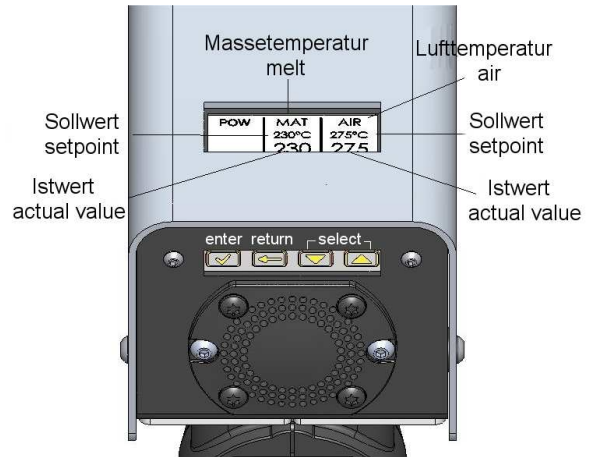

## Operating Instructions MUNSCH-controller (MM-Xtruder) from Software 1v56 onwards Bedienungsanleitung MUNSCH-Regler (MM-Xtruder) ab Software 1v56

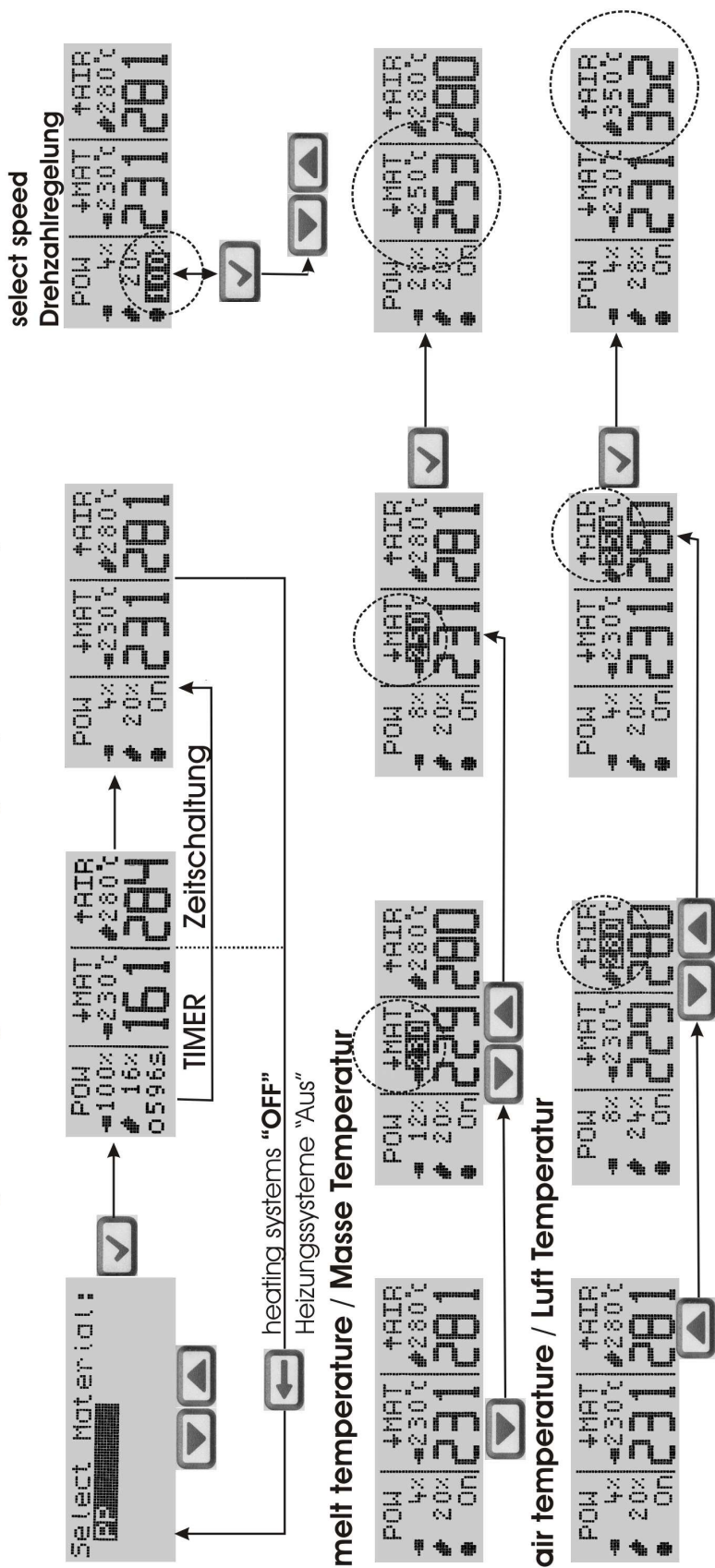

**Display design / Display Beschreibung**

ampere meter Ampere Anzeige	air / Luft	setpoint / Soll-Temp.	ENTER push-button and push-button for Select Speed	Bestätigungstaste und Taste zur Änderung der Motordrehzahl
power: MAT	+	actual value / Ist-Temp	RETURN push-button and push-button for switch off heating systems!	Zurücktaste und Ausschalten der Heizsysteme
power: AIR	+		DOWN push-button (Menue) and SELECT MELT for change the melt-temperature	Runter - Taste zur Änderung der Masstemperatur
	+		UP push-button (Menue) and Select AIR for change the air-temperature	Hoch - Taste zur Änderung der Lufttemperatur

Ton/off / speed control / Timer / error message  
 [Ein/Aus / Drehzahlregelung / Zeitschaltung / Fehlermeldung  
 Temperature meter drive unit, K03890 (no: 20)  
 Ampere > 3.0 = controller fault signal "OVERLD" (Drive overloaded at overload)  
 Ampere Anzeige der Antriebseinheit K03890 (Pos. 20)  
 Ampere > 3.0 = Anzeige am Regler "OVERLD" (Überlastung des Antriebs)



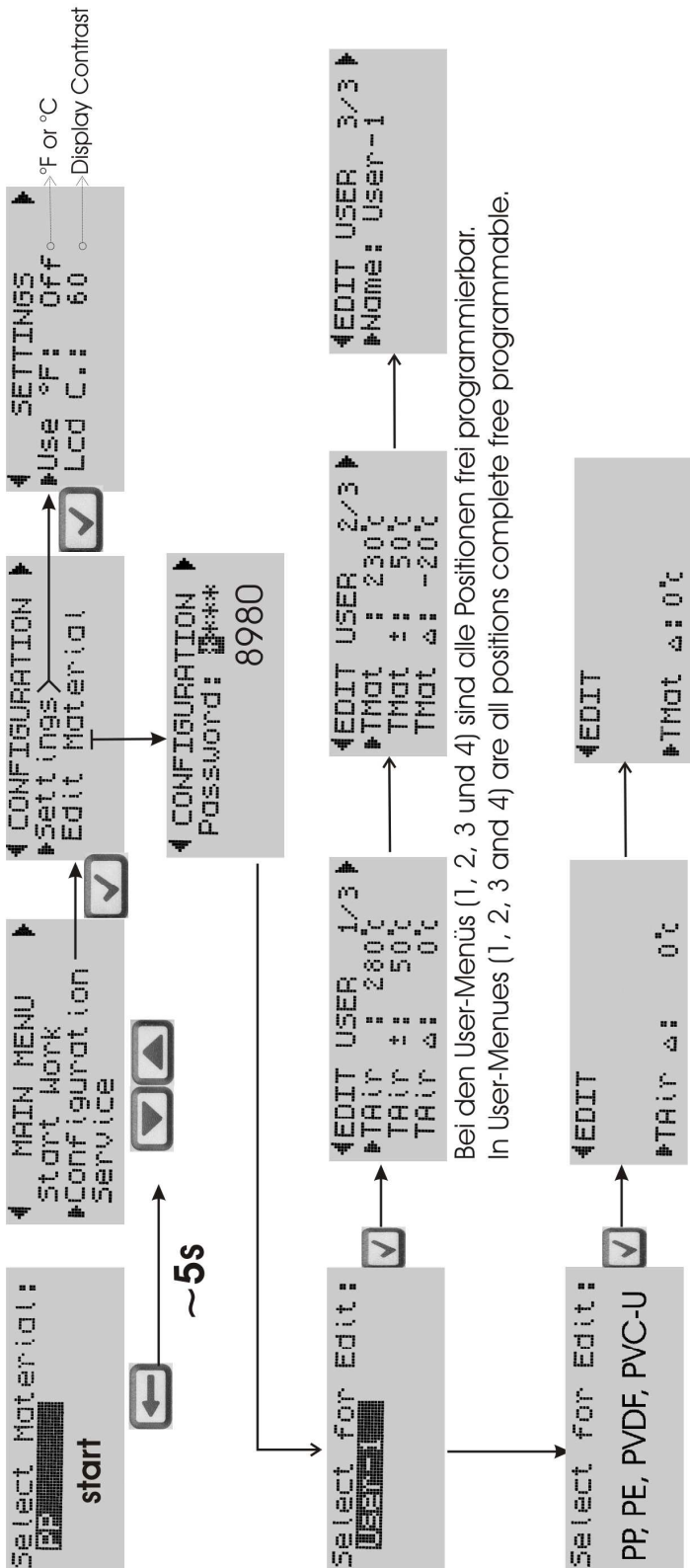

Bei den User-Menüs (1, 2, 3 und 4) sind alle Positionen frei programmierbar.  
In User-Menues (1, 2, 3 and 4) are all positions complete free programmable.

Bei den Hauptmenüs (PP, PE, PVDF und PVC-U) können nur die Abgleichwerte verändert werden!  
In the main-menus (PP, PE, PVDF and PVC-U) only the setoff's changeable.

TAir Δ: 0°C

Abgleich der Luft und Masse Temperaturen / Calibration from air and melt temperature:

- Messung der Temperatur mit externem Thermometer ist: measuring of temperature with external Temperature probe is:
- zu kalt, den Abgleich in den PLUS Bereich verschieben! - too cold, shift comparison into PLUS area!
- zu warm, den Abgleich in den MINUS Bereich verschieben! - too hot, shift comparison into MINUS area!

TAir	TAir	TAir	TMot	TMot	TMot	Name	User

**Notizen / Abgleiche user 1 - 4**

**notes / configuration user 1 - 4**

# Hand Extruder MM-Xtruder

## 6 Maintenance / Inspection



Pull mains connector before carrying out any maintenance and repair work on the hand extruder.

Maintenance and repair work on electrical tools may only be carried out by qualified electricians.



The hand extruder with the hot air hood must have cooled down to safe-to-touch temperature.

Observe the instructions in section "Safety".

Maintenance and repair work may only be carried out by qualified personnel or by our service staff.

To ensure the proper function of the hand extruder over its entire service life for its intended service, we recommend:

- to have all maintenance, inspection and mounting work carried out by authorized and qualified personnel who are familiar with the operating instructions,
- to always shut off the unit before carrying out any work on it,
- to remount and reactivate all safety and protective devices immediately after completion of the maintenance/repair work.

During maintenance and repair work, make sure that the hand extruder and its individual components are firmly positioned.

In addition to the operating instructions and the national and local accident prevention regulations applicable at the place of use, the acknowledged technical rules for safe and proper working practices must be observed.

Any working practices posing a safety risk are prohibited.



Activities other than those described in this section may only be performed at the Manufacturer's workshops!

### 6.1 Maintenance / inspection of hand extruder, type MM-Xtruder

- **CAUTION** After approx. 500 operating hours, the hand extruder including drive unit must be thoroughly cleaned and subjected to an inspection. This work may only be performed at the Manufacturer's workshops.
- **CAUTION** Cables, switches, plug-in connections must be inspected by qualified staff every three months (requirement according to VBG4); the inspection results must be documented.
- Use original spare parts only.

### 6.2 Dismantling

Prior to dismantling the hand extruder, pull the mains connector.

The hand extruder must be at ambient temperature.

Damaged mains connection cables must be completely replaced. "Mended" power cables pose a hazard to life and limb. Cable replacement is to be carried out by qualified electricians only.

The safety precautions described under sections "Safety" and "Malfunctions, Causes and Remedies" must be strictly adhered to.

For dismantling and assembly, the associated overall drawing must be strictly observed.

#### 6.2.1 Hand extruder, type MM-Xtruder

Overall drawing no. BA.MM-Xtruder-B.Rev-07  
Parts List - MM-Xtruder-B  
230 V = K03969B, K04326B  
115 V = K04180B, K04327B

Overall Drawing – Hand Extruder MM-Xtruder-A

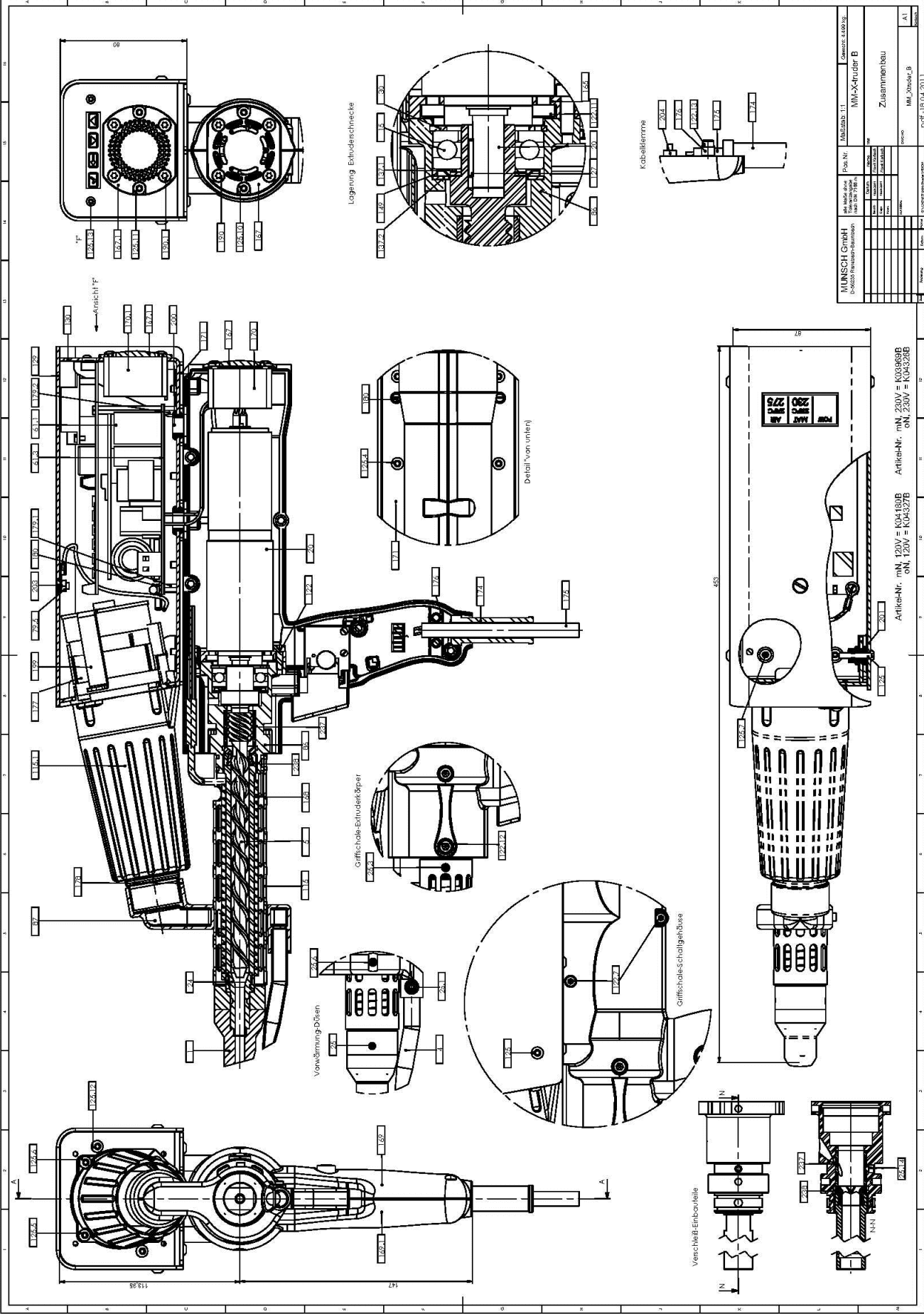

The drawing includes the following views and labels:

- Top View:** Shows the handle with dimensions 124.74, 132.95, 176.1, 182.31, 197.31, 198.3, and 200.3.
- Side View:** Shows the extruder head with dimensions 130, 150, 158, 162.1, 167.1, 172.1, 177, 181.4, 185.6, 190, 192.1, 196, 197.6, 200, 203.8, 207.9, 212.1, 216.1, 220.1, 224.1, 228, 232, 236, 240, 244, 248, 252, 256, 260, 264, 268, 272, 276, 280, 284, 288, 292, 296, 300, 304, 308, 312, 316, 320, 324, 328, 332, 336, 340, 344, 348, 352, 356, 360, 364, 368, 372, 376, 380, 384, 388, 392, 396, 400, 404, 408, 412, 416, 420, 424, 428, 432, 436, 440, 444, 448, 452, 456, 460, 464, 468, 472, 476, 480, 484, 488, 492, 496, 500, 504, 508, 512, 516, 520, 524, 528, 532, 536, 540, 544, 548, 552, 556, 560, 564, 568, 572, 576, 580, 584, 588, 592, 596, 600, 604, 608, 612, 616, 620, 624, 628, 632, 636, 640, 644, 648, 652, 656, 660, 664, 668, 672, 676, 680, 684, 688, 692, 696, 700, 704, 708, 712, 716, 720, 724, 728, 732, 736, 740, 744, 748, 752, 756, 760, 764, 768, 772, 776, 780, 784, 788, 792, 796, 800, 804, 808, 812, 816, 820, 824, 828, 832, 836, 840, 844, 848, 852, 856, 860, 864, 868, 872, 876, 880, 884, 888, 892, 896, 900, 904, 908, 912, 916, 920, 924, 928, 932, 936, 940, 944, 948, 952, 956, 960, 964, 968, 972, 976, 980, 984, 988, 992, 996, 1000.
- Front View:** Shows the extruder head with dimensions 68, 124.74, 132.95, 176.1, 182.31, 197.31, 198.3, and 200.3.
- Detail Views:**
  - Lagerung Extruderschnecke (Extruder bearing)
  - Kabelklemme (Cable ferrule)
  - Griffschale Extrudertripser (Extruder handle shell)
  - Griffschale-Schallgehäuse (Handle shell)
  - Vorwärmung Düsen (Preheating nozzle)
- Wiring Diagram:** Shows the electrical connection with terminals N (Neutral) and PE (Protective Earth).
- Specifications:**
  - Artikel-Nr. mN, 120V = K04180B
  - Artikel-Nr. oN, 120V = K04327B
  - Artikel-Nr. mN, 230V = K03968B
  - Artikel-Nr. oN, 230V = K04328B

# Hand Extruder MM-Xtruder

## Parts List - MM-Xtruder K03969B, K04326B, K04180B, K04327B

Hand Extruder, type MM-Xtruder; 230 V, 120V mN, oN				
CAD	Qty.	Unit	Ident No.	Designation
004.00	1,00	pc.	K03898	Preheat nozzle 18 x 4; MM
004.00	1,00	pc.	K04076	Preheat nozzle 12 x 4; MM
004.00	1,00	pc.	K0421 3	Preheat nozzle 10 x 4; MM
005.00	1,00	pc.	K03879	Extruder screw; MM
015.00	1,00	pc.	K02669	Axial deep-groove ball bearing; 51203
020.00	1,00	pc.	K03890	Drive unit; 40 / 42 MM
024.00	1,00	pc.	K03883	Nozzle; 40-6 MM
025.10	1,00	pc.	K03955	Set screw; M 5 x 6
025.14	1,00	pc.	K03955	Set screw; M 5 x 6
025.30	2,00	pc.	K03955	Set screw; M 5 x 6
025.60	1,00	pc.	K03955	Set screw; M 5 x 6
030.00	1,00	pc.	K00657	Circlip; I 35 x 1,5
061.10	1,00	pc.	K04808B (K04809B)	Melt/air temperature controller; 230 V, (120V) with integral motor LP MM
061.30	1,00	pc.	K04253	Insulating foil for MM-Xtruder; 0.25mm
086.00	1,00	pc.	K03880B	Extruder body; MM
087.00	1,00	pc.	K03891	Integrated air unit mount; 10°MM
115.00	1,00	pc.	K03886	Heat guard heating coil; MM
115.10	1,00	pc.	K03906	Heat guard air preheater; injection-moulded part MM
122.00	3,00	pc.	K03477	Allan screw ; M 4 x 12
122.11	4,00	pc.	K01454	Allan screw ; M 4 x 8
122.12	4,00	pc.	K03957	Allan screw ; M 5 x 5
122.13	2,00	pc.	K03477	Allan screw ; M 4 x 12
122.70	5,00	pc.	K00656	Allan screw ; M 4 x 16
124.10	1,00	pc.	K04110	Switch EBM 13; without speed control
125.00	4,00	pc.	K04595	Hexagon socket mushroom head screw; M 4 x 20 , ISO 7380 ULS
125.10	2,00	pc.	K03411	Hexagon socket mushroom head screw; M 4 x 8 , ISO 7380 ULS
125.11	2,00	pc.	K03411	Hexagon socket mushroom head screw; M 4 x 8 , ISO 7380 ULS
125.12	2,00	pc.	K03411	Hexagon socket mushroom head screw; M 4 x 8 , ISO 7380 ULS
125.13	2,00	pc.	K04023	Hexagon socket mushroom head screw; M 3 x6 , ISO 7380 ULS
125.40	8,00	pc.	K03411	Hexagon socket mushroom head screw; M 4 x 8 , ISO 7380 ULS
125.50	2,00	pc.	K03411	Hexagon socket mushroom head screw; M 4 x 8 , ISO 7380 ULS
125.60	2,00	pc.	K03411	Hexagon socket mushroom head screw; M 4 x 8 , ISO 7380 ULS
125.70	6,00	pc.	K03411	Hexagon socket mushroom head screw; M 4 x 8 , ISO 7380 ULS
127.00	1,00	pc.	K03309	Straight pin; 3 m6 x 10
129.00	1,00	pc.	K04786	Switchbox cover; anodized, mN MM
130.00	1,00	pc.	K0471 9	Switchbox lower part; black, fine-structured MM
137.10	2,00	pc.	K03959	Feather shim; 24 x 17 x 1
137.20	1,00	pc.	K03958	Feather shim; 25 x 35 x 1
149.00	1,00	pc.	K03960	Nilos ring; 6003 Z AV
165.00	1,00	pc.	K03881	Drive flange; MM
166.00	1,00	pc.	K03882B	Melting chamber; MM
167.00	1,00	pc.	K03887	Fan grille; injection-moulded part MM
167.10	1,00	pc.	K04738	Controller fan grille; injection-moulded part MM

**Parts List - MM-Xtruder K03969B, K04326B, K04180B, K04327B**

Article		Hand extruder, type MM-Extruder; 230 V, 120V mN, oN		
CAD	Qty.	Unit	Ident No.	Designation
168.00	1,00	pc.	K03889	Heating coil; 18x125 MM
169.00	1,00	pc.	K03892	Handle – left; injection-moulded part MM
169.10	1,00	pc.	K04738	Controller fan grille; injection-moulded part MM
170.00	1,00	pc.	K03894	Axial fan; 40 x 40 x 25 MM
170.10	1,00	pc.	K03894	Axial fan; 40 x 40 x 25 MM
171.00	2,00	pc.	K04721	Switch box connector; MM
173.00	1,00	pc.	K04259	Front plastic covering of display; for K-controller MM
174.00	1,00	pc.	K04137	Anti-kink sleeve 9-11; 5200 2020 MM
175.00	1,00	pc.	K04135	Cable, complete; 230V 3x1, 5mm <sup>2</sup> 5m long MM
176.00	1,00	pc.	K04136	Strain-relief clip; type B MM
177.00	1,00	pc.	K03964, K04244	Motor unit, 230V, (120V); Preheater MM
178.00	1,00	pc.	K04318, K04319	Complete heating system; 230 V – 2100W, (120V- 1600W)
178.10	1,00	pc.	K04258	Front plastic covering for keys; for K-controller MM
179.10	2,00	pc.	K04072	Spacer sleeve; M 3 x 8 Igew / Igew
179.20	2,00	pc.	K04074	Spacer sleeve; M 3 x 8 Igew / Agew
180.00	6,00	pc.	K03283	Slotted fillister head screw; M 3 x 5
190.00	4,00	pc.	K04256	Screw, PT; 4,0 x 10 mm, WN 1452, Torx
190.10	4,00	pc.	K04256	Screw, PT; 4,0 x 10 mm, WN 1452, Torx
199.00	1,00	pc.	K04722	Bracket for motor fan; MM
200.00	2,00	pc.	K04736	Cable sleeve; A10 - D2
201.00	4,00	pc.	K04737	Rubber-metal element; T-Flex Q4
203.00	1,00	pc.	K02632	Countersunk screw; M 4 x 10
204.00	3,00	pc.	K04739	Terminal strip; 1,5 - 2,5
237.00	1,00	pc.	K05539	Feeder sleeve
238.00	1,00	pc.	K05540	Cutting head

## 7 Malfunctions, Causes and Remedies

### 7.1 Trouble-shooting

The following table lists potential operating upsets of the hand extruder, possible causes and their remedies (fault diagnosis chart).



Should malfunctions occur which are not covered here or which cannot be traced back to the cause stated, please contact MUNSCH Kunststoff-Schweißtechnik GmbH.

Malfunction	Fault No.
Drive motor does not start	4, 5, 9, 10, 11, 12, 14, 15, 16, 17, 18, 19, 21
Drive motor switches off	5, 8, 9, 10, 11, 12, 14, 15, 16, 17, 18, 19, 21
No welding rod feed	1, 16, 17, 20
No extrudate conveyed out of welding shoe	1, 16
Extrudate output decreases during operation	1, 14, 16
No air supply	13
Integrated air supply system without function	22, 5
No hot air	2, 3, 4, 5, 18, 22
Hot air temperature below setpoint temperature	2, 3, 4, 8, 10, 14, 18, 22
Melt temperature below setpoint temperature	2, 3, 9, 11, 14
Extruder does not heat up	2, 3, 12, 22
Temperature above preset range	2, 3, 18, 19
Control fluctuates	3, 13, 19
Controller fault signal: OEAIR	2,10,19
Controller fault signal: OVERLD	22
Controller fault signal: OVHT	23
Controller fault signal: E:	9
Controller fault signal: Fan-ERROR	19,10
Controller signal: off	5,6,7,8,21

### 7.2 Fault diagnosis

Fault No.	Possible causes	Remedy
1	Smaller or too small a welding rod diameter	Use a larger welding rod diameter, if necessary
2	Temperature sensor defective	<sup>1)</sup>
3	Temperature controller defective	<sup>1)</sup>
4	Cable connections defective	Check cable connections <sup>1)</sup>
5	Hot air temperature below start interlock temperature	Allow hand extruder to heat up

1) Consult MUNSCH Kunststoff-Schweißtechnik GmbH

Fault No.	Possible causes	Remedy
6	Melt temperature below start interlock temperature	Allow hand extruder to heat up
7	Preheat time for hot air too short	Allow hand extruder to heat up
8	Preheat time for melt too short	Allow hand extruder to heat up
9	Heating tape defective	<sup>1)</sup>
10	Air supply not constant	- In the case of integrated air supply system: <sup>1)</sup>
11	Wrong rated voltage	<b>Rated voltage &gt; permissible voltage</b> Check mains voltage  <b>Rated voltage &lt; permissible voltage</b> Check mains voltage <sup>1)</sup>
12	Extension cable heats up	- Unroll cable reel - Check cable cross-section (see also section "Safety")
13	Extruder nozzle plugged with foreign matter	Clean extruder   <b>Extruder nozzle – left-hand thread</b>
14	Drive unit defective	<sup>1)</sup>
15	Electronic control defective	<sup>1)</sup>
16	Controller programming error	<sup>1)</sup>
17	Welding rod feed	Remove welding rod   Observe instructions in section "Maintenance"!  Observe instructions for hand extruder operation!
18	Carbon brushes of drive unit worn out	Replace carbon brushes <sup>1)</sup>
19	Hot air supply system defective	
20	No mains voltage	Check voltage supply
21	Heating circuit not activated	
22	Drive operates at overload	Heat up hand extruder, melt temperature too low
23	Temperature set on electronic controller too high	Allow unit to cool down

1) Consult MUNSCH Kunststoff-Schweißtechnik GmbH



# Hand Extruder MM-Xtruder

---

## 8 Technical Data

<b>Type designation</b>	<b>MM-Xtruder</b>
<b>Welding materials</b>	PP, PE, PVC, PVDF and other thermoplastics
<b>Welding rate, approx.</b>	Ø 3 mm: 0.6 kg/h PP Ø 3 mm: 0.6 kg/h PE
<b>Welding rod</b>	Welding rod Ø 3
<b>Application range</b>	Wall thicknesses 1-10 mm and film/sheeting welds
<b>Weight</b>	3.4 kg
<b>Drive</b>	230 V (115V) AC speed-controlled
<b>Extruder heating system</b>	875 W (220 W)
<b>Air heater</b>	2100 W (1600 W)
<b>Air supply</b>	Integrated air supply (Autoair)
<b>Control of melt temperature</b>	Temperature controller with concurrent momentary value and setpoint display
<b>Control of air temperature</b>	Temperature controller with concurrent momentary value and setpoint display
<b>Cold start protection</b>	Start temperature interlock and startup timer for melt and preheat air



# Warranty Certificate

.....  
.....  
.....

Name and address of Purchaser

**Type of unit:** Hand extruder  
**Type designation:** MM-Xtruder  
**Serial number:**  
**P.O. date:**

## Your warranty

MUNSCH Kunststoff-Schweißtechnik GmbH hereby warrants the unit to be free from defects in materials and workmanship from the date of its first acquisition. Should deficiencies resulting from defects in materials or workmanship be identified during the warranty period, the dealers will, in accordance with the following terms and conditions, repair the unit or, at their discretion, replace either the complete unit or the defective components without charging labour or material costs.

.....  
Dealer's stamp and signature

## Warranty

- 1 The Manufacturer warrants freedom from defects in materials and workmanship and state-of-the-art performance of the purchased article for a period of six (6) months from the date of delivery.
- 2 The Purchaser shall check the article delivered for completeness and freedom from defects immediately after receipt.
- 3 The Purchaser shall be entitled to the making good of defects and any resulting damage to other parts of the purchased article (remedial work).  
The procedure for claims under this warranty shall be as follows:
  - 3.1 The Purchaser may assert claims under this warranty either with his dealer or with a company authorized by the Manufacturer to provide services for the purchased article. The Purchaser shall give written notice of defects to the respective company immediately after such defects have been identified or shall have such defects registered by the respective company.
  - 3.2 Defects shall be promptly remedied in accordance with the technical requirements by either replacement or repair of the defective parts, the cost of the remedial work being for the account of the Manufacturer. Replaced parts shall become the property of the Manufacturer. If, as a result of the remedial work, additional maintenance measures are prescribed by the Manufacturer, the resulting costs including the costs of materials and lubricants shall be for the Manufacturer's account.
  - 3.3 For replacement parts installed within the scope of the remedial work, a warranty will be provided under the purchase contract, the warranty period for such parts ending on expiry of the warranty period of the object purchased.
  - 3.4 For the warranty to become effective, this warranty certificate must be produced for each repair.
- 4 If the defect cannot be remedied or if the Purchaser cannot be reasonably expected to accept any further attempts at making good the defect, the Purchaser may demand annulment (cancellation of the contract) or a price reduction (reduction of compensation) in lieu of remedial work. In such a case, the Purchaser shall not be entitled to any replacement.
- 5 Manufacturer's warranty obligations shall not be affected by a change in ownership of the purchased article.
- 6 Any damage incurred through the following acts or omissions of Purchaser shall be **expressly excluded** from this warranty:
  - 6.1 Purchaser's failure to report a defect pursuant to subsection 3.1 or to promptly provide an opportunity to remedy the defect following Manufacturer's request, or
  - 6.2 improper handling or overload operation of the purchased article, or
  - 6.3 prior repair, maintenance and servicing of the purchased article by a company not authorized by the Manufacturer, if the Purchaser can be reasonably expected to have known that such company was not authorized, or
  - 6.4 the installation of parts into the purchased article without having obtained Manufacturer's prior approval for such parts or the modification of the purchased article in a way not approved by the Manufacturer, or
  - 6.5 Purchaser's failure to observe the instructions given in the user's manual accompanying the purchased article (e.g. operation, maintenance and care), or
  - 6.6 Purchaser having removed the serial number or made it illegible.
- 7 Natural wear and tear shall be expressly excluded from the warranty.
- 8 Accidents, force majeure or other circumstances beyond the control of the Manufacturer, in particular damage caused by lightning, overvoltage, water, fire, etc. shall be excluded from the warranty.
- 9 All rights under this warranty shall become null and void on expiry of the warranty term pursuant to Section 1. For claims asserted within the warranty term but not settled by its expiry, the warranty shall remain effective until the respective defect has been remedied. The period of limitation shall be suspended for such claim.

**MUNSCH Kunststoff-Schweißtechnik GmbH**

Im Staudchen • D-56235 Ransbach-Baumbach  
P.O. Box 142 • D-56221 Ransbach-Baumbach  
Germany

Phone: +49 (0) 26 23-8 98-80

Telefax: +49 (0) 26 23-8 98-85

Internet: <http://www.munsch.de>

Email: [munsch@munsch.de](mailto:munsch@munsch.de)